

“设”想家
抗震建筑设计挑战赛

www.educationuk.cn/dynamicdesigns

合作伙伴 University of BRISTOL 同济大学 ARUP

1. Overview	1
2. Background on the Proposed Hospital.....	1
3. Specification for the Posters	2
4. The Dynamic Designs Discussion Forum	4
5. Deadlines and Important Dates for Stage 1	4
6. Preparing for the Challenge	5

1. Overview

Dynamic Designs Challenge is an Earthquake Engineering project created by the University of Bristol, and developed in partnership with the British Council. The Challenge requires a team of students to put together a proposal for a new hospital building in a highly seismic region. Students must consider the structural and architectural design of the building, its cost, its social and economic value to the region, and its value to an imaginary client, Mr Ivor Dunwell.

Your team has been invited to compete with other teams to bid for the design of the hospital. The challenge will be in two stages with some teams being eliminated at the end of Stage One.

For Stage One, teams must produce 2 posters: one on the structural design and cost of the building; the other on its architectural appearance and the benefits (e.g. social, economic) of the proposed hospital to the region, and to the client. Teams will be provided with support and guidance from University of Bristol experts, where they will be able to submit both preliminary and final designs for feedback before they make their final submission.

Stage Two will include only those teams with the best proposals, which will be judged from their posters. For Stage Two, teams must prepare for a final event on a day when they will present their proposals to a panel of experts, and construct models of their buildings which will be tested on a shaking-table (i.e. an earthquake simulator). The brief for Stage Two of the challenge will be sent to the qualifying teams.

The winning teams will be decided from Stage Two, based on the quality of their presentations and the performance of the model buildings on the shaking-table. Prizes will be presented for:

- Best presentation – to the team that presents the best proposal
- Most-Efficient Model – to the team whose model building performed “most-efficiently” on the shaking-table
- Overall winner - the overall winning team

2. Background on the Proposed Hospital

Mr Ivor Dunwell has become very wealthy through his coffee production and export business, which is based in the town of Mochalatte. Mochalatte is a remote town in the mountainous region of Cortado and



has a population of 12,000. This region is highly seismic – in the last century, there have been about 40 earthquakes of at least Magnitude 6.0.

Mochalatte can only be reached by one road which was constructed by building many bridges across valleys, tunnelling through mountains, and making cuttings in the steep mountain slopes. There is no airstrip in the town, but there is one tiny helicopter pad owned by Mr Dunwell for his small personal helicopter. The town is not prosperous, and many people suffer from a lack of education and poor health. There are not enough schools for the children and there is no hospital, only a small health clinic with 10 beds and a visiting doctor.

Mr Dunwell was born in Mochalatte to a poor family. He has made his wealth from the local land and the help of local workers, and wants to give something lasting back to the town. He has decided that he would like to pay for a new hospital. However, Mr Dunwell is a proud man and wants the hospital to be a landmark structure by which he will be admired and remembered.

Mr Dunwell remembers the devastating earthquake of 1980 that damaged many buildings in Mochalatte and killed and injured thousands of the inhabitants. He therefore wants the hospital to be designed to stand up to large earthquakes and wants the best earthquake engineering technology to be applied to its design. Not only does he require a design drawing for the building but he also wants a model of the building to be constructed and tested for earthquakes on a shaking-table (i.e. an earthquake simulator).

3. Specification for the Posters

3.1 Poster 1 “The Structure of the Model Building”

The purpose of this poster is for you to demonstrate to the judges the quality of your proposal for the structural, and earthquake resistant, design of your model for the hospital building.

This poster must include:

- Images of the structural design for the model building to be constructed
- Technical justification of your design
- A table showing the amount of each material to be used in the model, with the total cost for each material, and the total cost of the model. The cost of your model will represent the cost of the real building (see the “Model Specification” that you received with this brief).

Images of the structural design should only show the structural frame, or “skeleton”, of your building and not the architectural features such as the cladding, doors or windows. The structural frame includes elements that carry loads and forces, such as columns, beams and other elements that provide the building’s strength. An example of a technical structural drawing is shown in Figure 1.

You can add any other information to the poster that you feel is relevant, e.g. an overview of options that you considered for your design.

You have been provided with the “Model Specification”. To qualify for Stage Two, your team must demonstrate (e.g. using images with dimensions) that you have adhered to this specification.

Images can include sketches, technical drawings (e.g. elevations, plans, isometric drawings) and photographs of test models constructed by your team. The dimensions of the model must be clearly indicated and must include the overall floor dimensions, the overall height of the model, and the distance between floors. Example images are shown in Figure 1.

3.2 Poster 2 “The Value of the Building”

The purpose of this poster is for you to justify to the judges the balance between the total cost of your proposed building and its value and benefits to the region and Mr Dunwell.

This poster must include:

www.educationuk.org/china



- Architectural images of **ONLY** the exterior of your proposed hospital
- The total cost of the building (i.e. the same as the total cost of the model)
- The main social and economic benefits of the hospital to the town and region
- The benefits and value of the building design to Mr Dunwell
- You can add any other information that you feel is relevant

The architectural image of your building must show all storeys of the real building (Note that the scale model of the building will not include all storeys – for further information on this, see the “Model Specification”). Your architectural images will be artistic representations of how the building will appear from the outside when it is complete.

3.3 Format for posters

- All text on the posters must be wholly in English.
- Posters must be of size A2 (i.e. 420 x 594 mm).
- Posters can be produced in landscape or portrait.
- Posters can be prepared in either of the following ways:
 - Electronically in a software package, e.g. Microsoft PowerPoint
 - By hand, and then digitally photographed or scanned into an electronic file
- The minimum size of printed font must be:
 - 16pt for electronically prepared posters
 - 6mm for hand prepared posters
- Each poster must display the following information
 - The title of the poster, i.e. “The Structure of the Model Building” or “The Value of the Building”
 - The name of your educational institution (e.g. university)
 - The allocated number for your team and team name.
 - The names of your team members
- Posters must be submitted as electronic files in jpg, pdf or ppt format.
- The size of the electronic file for each poster must not exceed 10 Mbytes.
- The electronic file of your poster must produce a clear readable printout at A4 size (i.e. 210 x 297 mm). Please note, we would like to use posters that can be printed clearly at A3 or A2 size for displays, so we would prefer it if you can achieve that. If you can't, your team will not be penalised.

3.4 Judging Criteria for Posters

Poster 1 will be judged on the images (35%), technical content (35%), layout and style of poster (15%), and good use of English (15%).

Poster 2 will be judged on the architectural image of building (30%), the balance between the cost of the structure and how the region and Mr Dunwell will benefit from it (40%), layout and style of poster (15%), and good use of English (15%).



4. The Dynamic Designs Discussion Forum

You will be registered to use the Dynamic Designs Discussion Forum at

www.ideers.bris.ac.uk/dynamicdesigns/forum.html

Your team will be allocated a team number and a University of Bristol expert who will comment on your ideas for the structural design of the hospital.

The Discussion Forum provides you with the following facilities:

- A Public Discussion Area
 - In this area, any team can post general questions on the challenge and for clarification of the rules. All other teams will be able to see the answers to your questions. You will also find a FAQ section here.
- A Private Area for your team
 - Only members of you team and your University of Bristol expert will have access to this area. Each member of your team will be given a login username and password. You can use the Private Area for discussion between your team members. You will also use this area to upload the submissions on your design ideas to your expert, and to upload your two posters for judging

5. Deadlines and Important Dates for Stage 1

Date	Activity
20 th – 22 nd September	<p>During this time, your team may upload, onto the Dynamic Designs Discussion Forum, ONLY one submission on the preliminary ideas for just the design for the model of your building to your University of Bristol expert for their comments. Your submission must be uploaded by Wednesday 22nd of September 6.00 p.m. (local time). You will receive a response by 27th September.</p> <p>Your submission MUST NOT exceed two A4 pages of sketches and notes. All notes must be written in English.</p>
1 st - 4 th October	<p>During this time, your team may upload, onto the Dynamic Designs Discussion Forum, ONLY one submission on the final ideas for just the design for the model of your building to your University of Bristol expert for their comments. Your submission must be uploaded by Monday 4th of October 6.00 p.m. (local time). You will receive a response by 7th October.</p> <p>Your submission MUST NOT exceed two A4 pages of sketches and notes. All notes must be written in English.</p>
15 th October	<p>Deadline for all teams to submit posters – Friday 15th of October 6.00 p.m. (local time)</p> <p>You MUST submit your two posters for judging by this deadline</p>
1 st November	<p>Your team will be informed on whether or not it has qualified for Stage Two.</p> <p>The Stage Two Brief will be sent to the qualifying teams</p>



6. Preparing for the Challenge

6.1 Research

For this challenge, it is recommended that your team conducts some research on:

- Earthquakes
- Their effects on communities and structures
- The behaviour of buildings during earthquakes
- Designing earthquake resistant buildings
- Building architecture

There are some very good web resources on the above. The Dynamic Designs Challenge pages, on the University of Bristol web-site, give links to other useful web-sites. See www.ideers.bris.ac.uk/dynamicdesigns

Your research will be especially valuable when preparing for Stage One, regarding the posters, and for Stage Two, in relation to the development of the presentations.

6.2 Making Trial Models

In preparing the structural design for the model building for Stage One, it is recommended that your team builds and tests some trial models before submitting your posters. Teams that qualify for the final can also develop their designs further in Stage Two, and may want to build and test more trial models, as well as practising their construction technique for the final event. If you wish to construct models in your institution, you will need the following materials and equipment:

- Materials for one model
 - A base board on which to fix the model. The base board should be 25cm square and cut from 6mm thick MDF (Medium Density Fibre) board.
 - 30 rectangular strips of MDF cut from 6mm thick board. The strips must be 60cm long with cross-sectional dimensions of 4mm by 6mm.
 - Ball of cotton string.
 - Sheets of plain paper
 - Hot melt glue sticks.
- Equipment for constructing models
 - Scissors
 - Hot melt glue gun
 - Junior hacksaw
 - Tape measure or a 1 metre ruler
 - A drill with an 8mm diameter bit to drill holes in the MDF base board

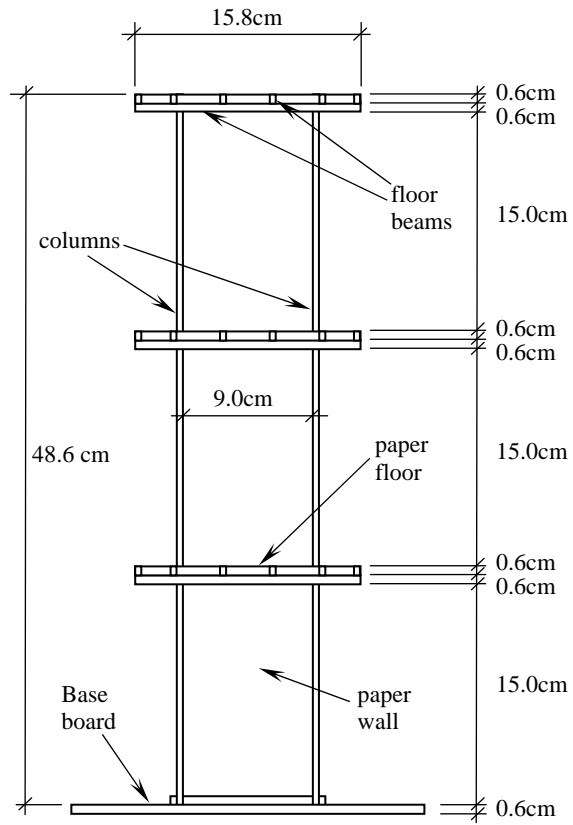
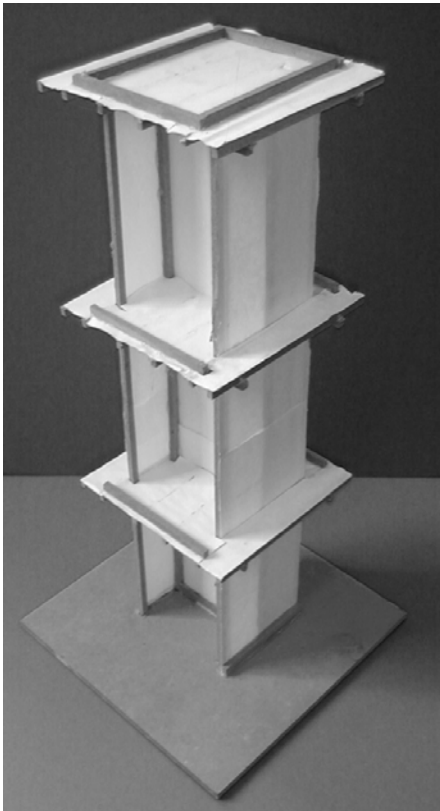

Figure 1: Photograph of an example model and technical elevation drawing showing dimensions